



SPEED QUEEN® ON-PREMISES LAUNDRY SOLUTIONS

# Single Premium Tumble Dryer

ST120  
120 lb (54 kg)

## Premium Tumble Dryers

Our single pocket tumble dryers are designed with fewer moving parts, so that you'll face fewer maintenance problems and less wear and tear. We make it easier with a large, easy-to-clean lint compartment and a heavy-duty door hinge designed to withstand heavy usage.

- High-performance heater box increases energy efficiency, reduces drying times and provides a more comfortable operating environment.
- Precise drying performance with OPT (over-dry prevention technology).

- Large easy-to-clean lint compartment.
- Reversing option available.
- Quantum™ gives you complete laundry control to reduce costs and increase throughput.

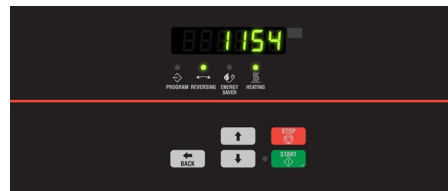

### Quantum® Gold

Revolutionary Quantum® Gold technology combines equipment controls, programming and wireless networking into one complete OPL management system, giving you total control over your laundry room from any computer, anywhere in the world. Advanced diagnostics and audit data reports help you catch errors before they become bigger issues. Quantum Gold is designed to help you reduce costs, decrease your downtime and increase your throughput.

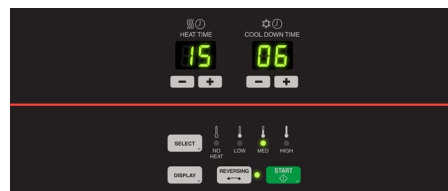

### Dual Digital

With features that include one touch cycle repeat, automatic extended tumble and a large digital countdown display, it's simple to set your drying time, temperature and cool down on the fly.

# Single Premium Tumble Dryer

## Specifications

		<b>ST120</b>	
Control Option		Quantum Gold, Dual Digital	
Capacity - lb (kg)		120 (54)	
Overall Width - in (mm)		46.1 (1170)	
Overall Depth - in (mm)		67.9 (1725)	
Overall Height - in (mm)		85.7 (2175)	
Cylinder Diameter - in (mm)		44 (1120)	
Cylinder Depth - in (mm)		41 (1040)	
Cylinder Volume - cu. ft (liters)		36.1 (1020)	
Door Opening Size - in (mm)		26.9 (683)	
Energy Data		Gas Models - Per Pocket 270,000 Btu/hr	
		Steam Models - Per Pocket 187,560 Btu/hr	
		Electric Models 60kW	
Gas Connections - in (npt)		1	
Plumbing Connections - Steam - in (npt)		0.75	
Air Outlet - in (mm)		10 (254)	
Motor - HP		Fan 1.5	
		Cylinder 1.5	
Airflow - cfm		1400	
Electrical Specs - amps	Gas & Steam		
	Q	200-240V/50/60/3	7
	N	440-480V/50/60/3	4
	P	380-415V/50/60/3	4
	Electric		
	G	230-240V/50/60/3	147
	H	380V/50/60/3	94
	J	400-415V/50/60/3	86
K	440V/50/60/3	82	
L	460-480V/50/60/3	75	
Shipping Dimensions Approx.- in (mm)		Width	48 (1220)
		Depth	71.5 (1820)
		Height	90 (2290)
Net Weight - lb (kg)		Gas	1220 (555)
		Electric	1250 (575)
		Steam	1330 (605)
Shipping Weight - lb (kg)		Gas	1290 (585)
		Electric	1320 (600)
		Steam	1400 (635)
Agency Approvals		CSA	

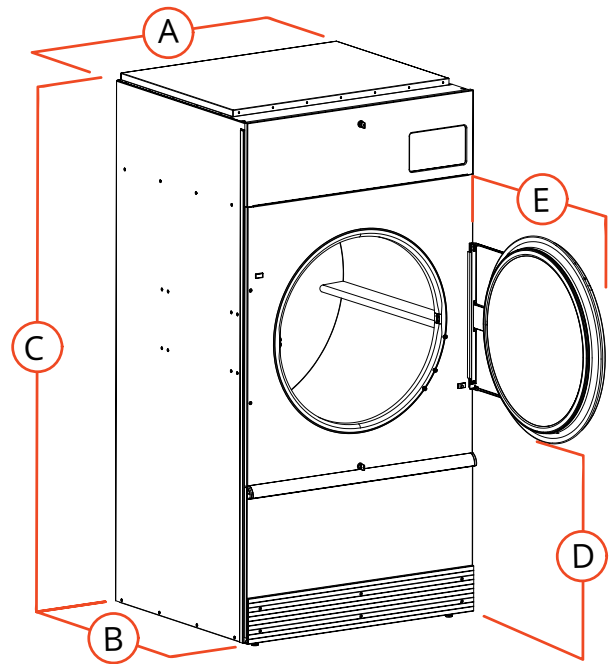

A.	Overall Width - in (mm)	46.1 (1170)
B.	Overall Depth - in (mm)	67.9 (1725)
C.	Overall Height - in (mm)	85.7 (2175)
D.	Door Bottom to Floor - in (mm)	31.4 (800)
E.	Door Swing - in (mm)	32.5 (825)

Tumble dryer models are made to suit a variety of electrical service characteristics. See your Speed Queen distributor for specifications.

For further details on installation, refer to Installation, Operation and Maintenance instructions supplied with the tumble dryer. Amperage ratings available in Installation Manual.

For the most accurate information, the installation guide should be used for all design and construction purposes. Due to continuous product improvements, design and specifications subject to change without notice. The quality management systems at Alliance Laundry Systems are registered to ISO 9001.