

MWF27J8

60 LB. (27KG) CAPACITY
SUSPENDED WASHER-EXTRACTOR

SPECIFICATION SHEET

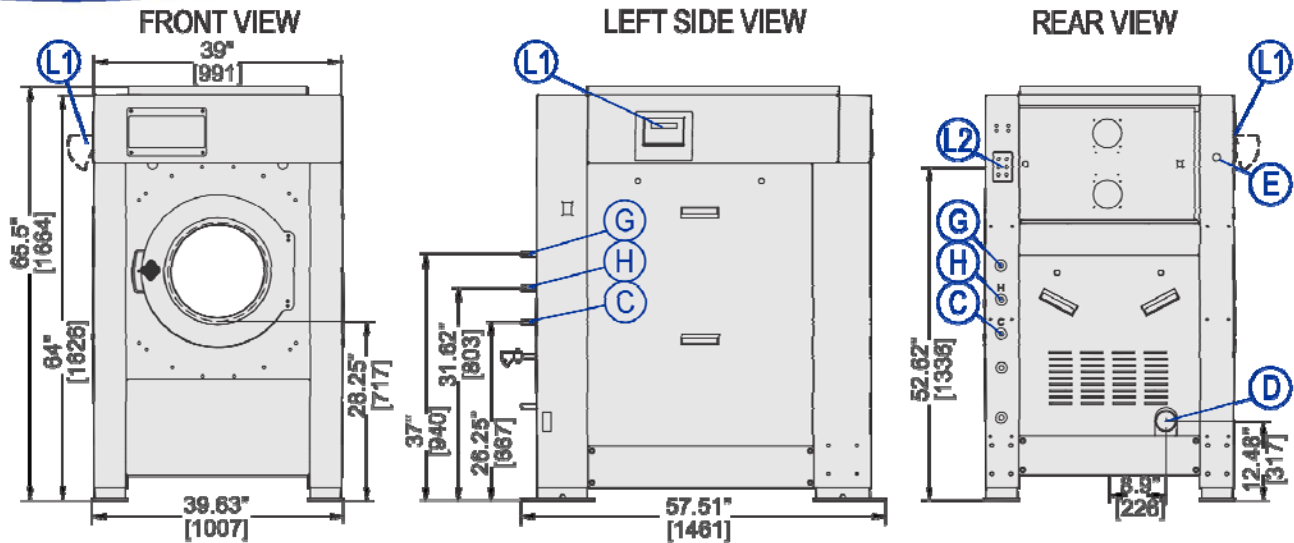

ANCHORING DETAIL

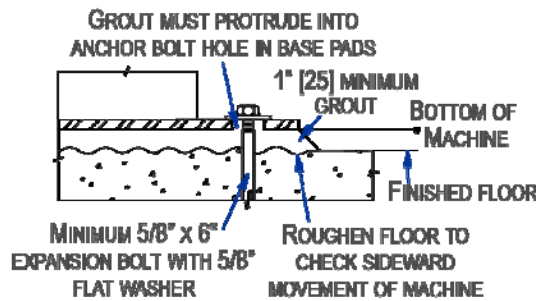

LEGEND

C	Cold water inlet .75" (19 mm) GHT
D	Drain to sewer 3" (76 mm) PSJ
E	Electrical connection
F	Foundation pads; anchor bolt holes 1.06" (27mm)
G	Chemical flush .75" (19 mm) NPT
H	Hot water inlet .75" (19 mm) GHT
L1	Liquid soap inlets
L2	Soap chute

MECHANICAL SPECIFICATIONS

ELECTRICAL SPECIFICATIONS

Capacity – lb. (kg)	60 (27)
Cylinder Diameter x Depth – ins (mm)	30 x 22 (762 x 559)
Cylinder Volume – cu. ft. (L)	9 (255)
Door Opening – in. (mm)	15.63 (397)
Machine Dimensions (W x D x H) – in. (mm)	39.63x57.51x65.5 (1007x1461x1664)
Shipping Dimensions (W x D x H) – in. (mm)	45.28x59.06x71.97 (1150x1500x1828)
Motor – HP (kW)	5 (3.7)
Wash Speeds – RPM	38-43
Distribution Speed – RPM	68
Extraction Speeds – RPM	390-840
Extraction G-Force	300
Static Weight – lb. (kg) ✧	2137 (969)
Max. Dynamic Load RMS – lb. (kg) ✧	307 (139)
Frequency (Hz)	14
Water Pressure ^(Required) psi (bar)	10-75 (0.69-5.17)
Water Valve Cv Rating	4.66 (17.64)
Minimum Recommended Distance Between Machines – in. (mm)	12 (305)

Voltage	Running Amps	Fuse (Amps)	Circuit Breaker (Amps)
220/3/50-60	12	FRN20	20
208, 240/3/60	10	FRN20	20
380/3/50-60	8	FRS15	15
415/3/50	7	FRS15	15
480/3/60	6	FRS15	15

See Fuse and Wire Size manual MAEFUSE1BE for safety information. Contact factory regarding single phase availability.

▼ See dimensional drawing for complete details.

✧ It is the sole responsibility of the owner/user to assure that the floor and/or any other supporting structure exceeds not only all applicable building codes, but also that the floor and/or any other supporting structure for each washer-extractor or group of washer-extractors has sufficient strength and rigidity (i.e., a natural or resonant frequency many times greater than the rotational machine speed with a reasonable factory of safety) to support the weight of all the fully loaded machine(s) including the weight of the water and goods, and including the published 360° rotating sinusoidal RMS forces that are transmitted by the machine(s). Contact the factory for additional machine data for use by a structural engineer.



MWF27J8

60 LB. (27KG) CAPACITY
SUSPENDED WASHER-EXTRACTOR

SPECIFICATION SHEET

Standard Features:

- RinSave® water saving technology
- 7 speeds (2 wash, 1 distribution, 1 RinSave, 3 extract)
- E-P PLUS® programmable controller
- Back-lit LCD display
- Single-motor inverter drive
- Tall, lifting ribs
- Tapered roller bearings
- High M.A.F. (Mechanical Action Factor)
- Large cylinder perforations
- Fresh-water flushing chemical manifold
- Six (6) liquid chemical injection ports
- Control reads in English/second language
- 5-year limited warranty on frame, cylinder & shell



Optional Features:

- Steam
- Electric heat
- 5 compartment flushing supply injector

Why Purchase Milnor?

- RinSave® water saver in conjunction with large cylinder perforations provides more efficient rinsing. **BENEFIT: Saves water, energy, and time.**
- Larger cylinder volume than most competitive similar sized washer-extractors provides *greater productivity*. More linen washed per day, or fewer hours required to process. **BENEFIT: Saves labor.**
- Greater cylinder perforated-area generates *better wash quality, better rinsing and better extraction*. **BENEFIT: Better extraction saves dryer fuel.**
- Faster process times reduce fabric wear, promoting *longer linen life!* **BENEFIT: Saves linen replacement costs.**
- Tall perforated ribs provide excellent lift and high drop. **BENEFIT: Greater mechanical action (M.A.F.) leads to better wash quality.**
- 300-G high extract provides excellent moisture removal. Lower extract speeds are available for uniforms, delicate textiles and blended fabrics. **BENEFIT: Better extraction saves dryer fuel.**
- E-P Plus Controller with back-lit LCD display allows operator to choose formulas from real words, not codes. Standard controller features English/Spanish (other languages optional). Controller also provides diagnostic and error messages. Shortens training time of new employees. **BENEFIT: Fewer operator errors.**
- Superior product support through local, highly-skilled dealers. **BENEFIT: Faster repairs mean less downtime.**



Safe chemical injection



Superior cylinder design



SmoothCoil™ 4 Point
Suspension System

Contact Milnor for your local, authorized dealer:

Pellerin Milnor Corporation
P.O. Box 400 • Kenner, LA 70063
t: 504-467-9591 • f: 504-468-3094

