

# 36026 V7Z

100 LB. (45KG) CAPACITY  
RIGID-MOUNT WASHER-EXTRACTOR

## SPECIFICATION SHEET

FRONT VIEW

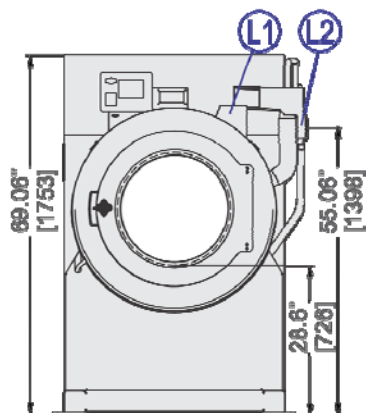

RIGHT SIDE VIEW

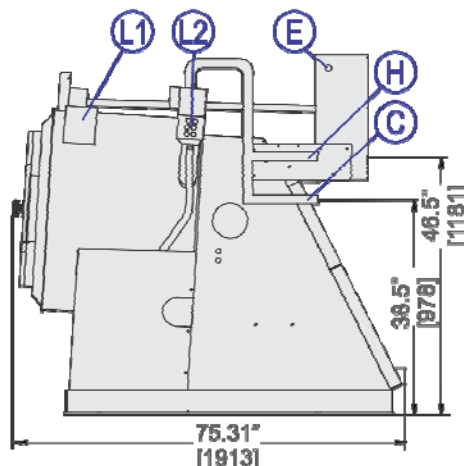

REAR VIEW

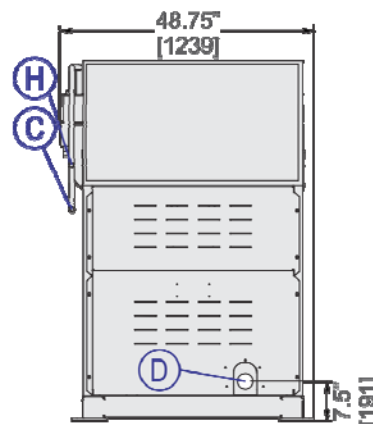

FOUNDATION VIEW

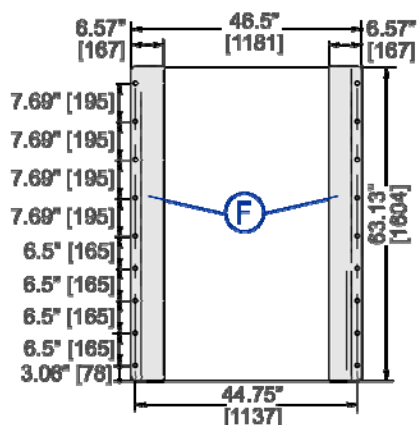

ANCHORING DETAIL

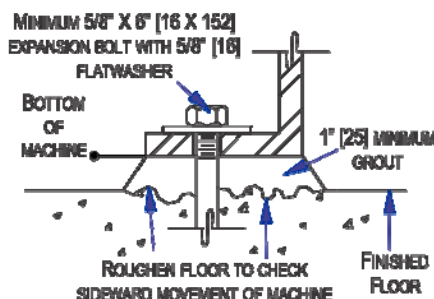

FLOOR REQUIREMENT 12" MINIMUM  
RECOMMENDED ▼, ◆, ■

LEGEND

C	Cold water inlet, .75" (19 mm) NPT
D	Drain to rear, 3" (76 mm) pipe socket joint
E	Main electrical connection
F	Foundation base pads. Anchor bolt holes are .8125" (21 mm) diameter
H	Hot water inlet, .75" (19 mm) NPT
L1	Standard soap chute
L2	Liquid supply inlets

### MECHANICAL SPECIFICATIONS

Capacity – lb. (kg)	100 (45)
Cylinder Diameter x Depth – in. (mm)	36 x 26 (914 x 660)
Door Opening – in. (mm)	21.69 (551)
Cylinder Volume – cu. ft. (L)	15.3 (434)
Machine Dimensions (W x D x H) – in. (mm)	48.75 x 75.31 x 69 (1239 x 1913 x 1753)
Shipping Dimensions (W x D x H) – in. (mm)	86 x 60 x 76 (2184 x 1524 x 1930)
Motor – HP (kW)	10 (7.45)
Wash Speeds – RPM	25-45
Distribution Speed – RPM	65
Extraction Speeds – RPM	200-766
Extraction G-Force	300
Static Weight – lb. (kg) ◆	2995 (1359)
Max. Dynamic Load RMS- lb. (kg) ◆	4424 (2007)
Frequency (Hz)	11.67
Water Pressure (Required) – psi (bar)	10-75 (.68-5.1)
Water Valve CV Rating	6.5 (25)
Minimum Recommended Distance Between Machines – in. (mm)	12 (305)

### ELECTRICAL SPECIFICATIONS

Voltage	Running Amps	Fuse (Amps)	Circuit Breaker (Amps)
208-240/3/60	21/19	FRN30	30
220/3/50	20	FRN30	30
220/3/60	20	FRN30	30
380/3/50-60	12	FRS20	20
415/3/50	11	FRS15	15
480/3/60	8	FRS15	15

See Fuse and Wire Size manual MAEFUSE 1BE for safety information. Contact factory for electrical specifications if equipped with Electric Heat option. Contact factory for single phase availability.

▼ See dimensional drawing for complete details.

◆ The floor and/or other support components must have sufficient strength (and rigidity with due consideration for natural or resonant frequency thereof) to withstand the fully loaded weight of the machine including the goods, the water, and any repeated sinusoidal (rotating) forces generated during its operation. Contact the factory for additional machine data for use by a competent soil and/or structural engineer.

■ Machine bases made from concrete should either be part of a monolithic pour or should be tied into foundation and not isolated from existing floor.



# 36026 V7Z

100 LB. (45KG) CAPACITY  
RIGID-MOUNT WASHER-EXTRACTOR

## SPECIFICATION SHEET

### Standard Features:

- RinSave® water saving technology
- 7 speeds (2 wash, 1 distribution, 1 RinSave, 3 extract)
- MilTouch™ programmable control
- Back-lit LCD display
- Single-motor inverter drive
- Tall, lifting ribs
- Tapered roller bearings
- High M.A.F. (Mechanical Action Factor)
- Large cylinder perforations
- Fresh-water flushing chemical manifold
- Auto tension V-belt drive
- Six (6) liquid chemical injection ports
- Control reads in English/second language
- 5-year limited warranty on frame, cylinder & shell



### Optional Features:

- Steam
- Electric Heat
- 5 compartment flushing supply injector
- Prison package

### Why Purchase Milnor?

- RinSave® water saver, in conjunction with large cylinder perforations, provides more efficient rinsing. **BENEFIT: Saves water, energy, and time.**
- Larger cylinder volume than most competitive similar sized washer-extractors provides *greater productivity*. More linen washed per day, or fewer hours required to process. **BENEFIT: Saves labor.**
- Faster process times reduce fabric wear, promoting *longer linen life!* **BENEFIT: Saves linen replacement costs.**
- Tall perforated ribs provide excellent lift and high drop. **BENEFIT: Greater mechanical action (M.A.F.) leads to better wash quality.**
- 300G extract provides excellent moisture removal. Lower extract speeds are available for uniforms, delicate textiles and blended fabrics. **BENEFIT: Better extraction saves dryer fuel.**
- MilTouch™ touch screen control, utilizing resistive touch screen technology and full VGA resolution, has a clear and informative display which shows current machine status info including total formula time and time elapsed. Formulas can be developed on a PC, saved to USB external memory and uploaded with a screen touch. Controller also provides intuitive fault diagnosis and relevant troubleshooting suggestions. **BENEFIT: Fewer operator errors.**
- Superior product support through local, highly-skilled dealers. **BENEFIT: Faster repairs mean less downtime.**



Safe chemical injection



Superior cylinder design



Solid industrial frame

Contact Milnor for your local, authorized dealer:

Pellerin Milnor Corporation  
P.O. Box 400 • Kenner, LA 70063  
t: 504-467-9591 • f: 504-468-3094

