

MWR27X5

60 LB. (27KG) CAPACITY
RIGID-MOUNT WASHER-EXTRACTOR

SPECIFICATION SHEET

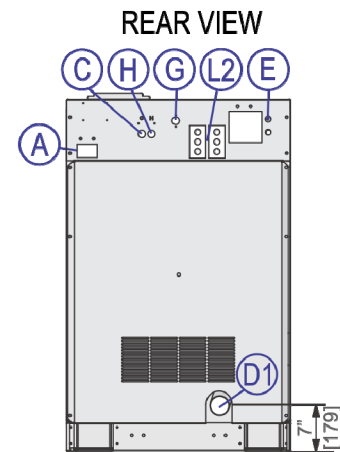
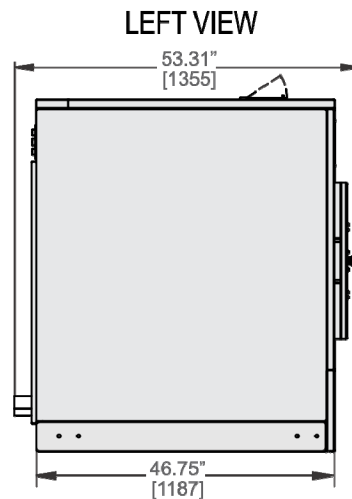
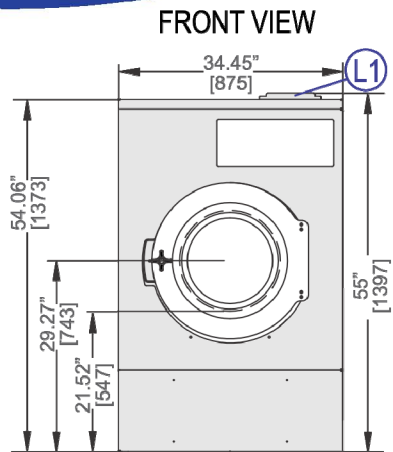

FOUNDATION PLAN

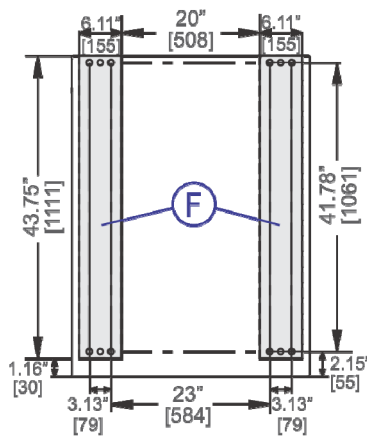

ANCHORING DETAIL

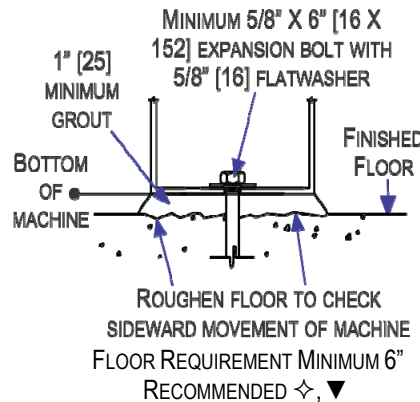

LEGEND

A	Vacuum breaker
C	Cold Water inlet
D1	Drain 3" (76 mm) ID hose connection
E	Main Electrical Connection
F	Foundation pads, anchor bolt holes .625" (15.87 mm) diameter
G	Hot water inlet for soap chute
H	Hot water inlet, .75" (19 mm) GHT
L1	Standard soap chute
L2	Peristaltic inlet, 5 ports standard

MECHANICAL SPECIFICATIONS

Capacity – lbs (kg)	60 (27)
Cylinder Diameter x Depth – ins (mm)	30 x 22 (762 x 558)
Cylinder Volume – cu. ft. (L)	9 (255)
Door Opening – ins (mm)	15.5 (394)
Machine Dimensions (W x D x H) – ins (mm)	34.45 x 53.31 x 55 (875 x 1355 x 1397)
Shipping Dimensions (W x D x H) – ins (mm)	36 x 56 x 61 (91 x 142 x 155)
Motor – HP (kW)	3 (2.23)
Wash Speed – RPM	38
Distribution Speed – RPM	68
Extraction Speed – RPM	485
Extraction G-Force	100
Static Weight – lbs (kg) ⚡	1641 (746)
Max. Dynamic Load RMS – lbs (kg) ⚡	1202 (546)
Frequency (Hz)	8.08
Water Pressure (Required) – psi (bar)	5-75 (0.3-5.1)
Water Valve CV Rating – gal/min (L/min)	3.35 (15.23)
Minimum Recommended Distance Between Machines – ins (mm)	0

ELECTRICAL SPECIFICATIONS

Voltage	Running Amps	Fuse (Amps)	Circuit Breaker (Amps)
220/3/50	7	FRN15	15
208, 240/1/60	9, 8	FRN20	20
208, 240/3/60	8, 7	FRN15	15
380/3/50-60	4.5	FRS15	15
415/3/50	4.5	FRS15	15
480/3/60	3.5	FRS15	15

See Fuse and Wire Size manual MAEFUSE1BE for safety information.

▼ See dimensional drawing for complete details.

⚡ The floor and/or other support components must have sufficient strength (and rigidity with due consideration for natural or resonant frequency thereof) to withstand the fully loaded weight of the machine including the goods, the water, and any repeated sinusoidal (rotating) forces generated during its operation. Contact the factory for additional machine data for use by a competent soil and/or structural engineer.



MWR27X5

60 LB. (27KG) CAPACITY

RIGID-MOUNT WASHER-EXTRACTOR

SPECIFICATION SHEET

Standard Features:

- 3 speeds
- E-P Express® controller
- Single-motor inverter drive
- Tall, lifting ribs
- Sealed ball bearings
- High M.A.F. (Mechanical Action Factor)
- Large cylinder perforations
- Fresh-water flushing chemical manifold
- Auto tension V-belt drive
- Five (5) liquid chemical injection ports
- 5-year limited warranty on frame, cylinder & shell



Optional Features:

- Lint trap
- Mounting base

Why Purchase Milnor?

- Larger cylinder volume than most competitive similar sized washer-extractors provides *greater productivity*. More linen washed per day, or fewer hours required to process. **BENEFIT: Saves labor.**
- Greater cylinder perforated-area generates *better wash* quality, *better rinsing* and *better extraction*. **BENEFIT: Better extraction saves dryer fuel.**
- Faster process times reduce fabric wear, promoting *longer linen life!* **BENEFIT: Saves linen replacement costs.**
- 100-G extract and large cylinder perforated area provide excellent moisture removal. **BENEFIT: Better extraction saves dryer fuel.**
- Tall perforated ribs provide excellent lift and high drop. **BENEFIT: Greater mechanical action (M.A.F.) leads to better wash quality.**
- E-P Express Controller with back-lit LCD display allows operator to choose formulas from real words, not codes. Standard controller features English/Spanish (other languages optional). Controller also provides diagnostic and error messages. Shortens training time of new employees. **BENEFIT: Fewer operator errors.**
- Superior product support through local, highly-skilled dealers. **BENEFIT: Faster repairs mean less downtime.**



Safe chemical injection



Superior cylinder design

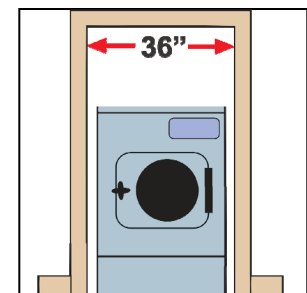

Fits through 3'-0" door

Contact Milnor for your local, authorized dealer:

Pellerin Milnor Corporation
P.O. Box 400 • Kenner, LA 70063
t: 504-467-9591 • f: 504-468-3094

