

MWR16E5

35 LB. (16KG) CAPACITY
RIGID-MOUNT WASHER-EXTRACTOR

SPECIFICATION SHEET

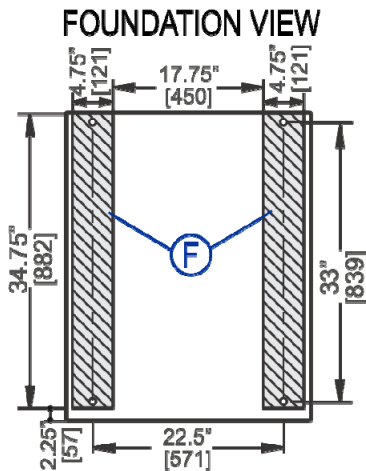
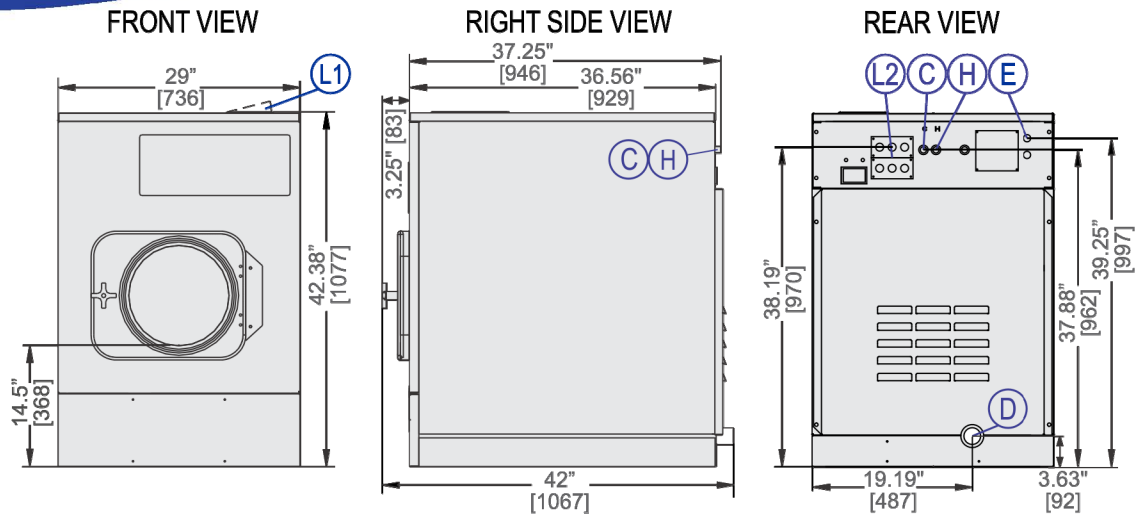

ANCHORING DETAIL

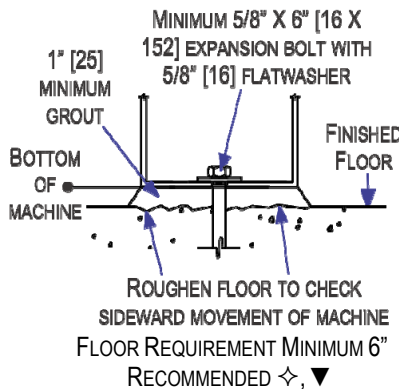

LEGEND

C	Cold water inlet, .75" (19 mm) GHT
D	Drain 2" (51 mm) ID hose connection
E	Electrical connection
F	Foundation pads; Anchor bolt holes .8125" (21 mm)
G	Chemical flush, .75" (19 mm) GHT connection
H	Hot water inlet, .75" (19 mm) GHT
L1	Soap chute
L2	Liquid supply inlets

MECHANICAL SPECIFICATIONS

Capacity – lbs (kg)	35 (16)
Cylinder Diameter x Depth – ins (mm)	23 x 18 (584 x 457)
Cylinder Volume – cu. ft. (L)	4.3 (121)
Door Opening – ins (mm)	12 (305)
Machine Dimensions (W x D x H) – ins (mm)	29 x 42 x 42.38 (736x1067x1077)
Shipping Dimensions (W x D x H) – ins (mm)	31 x 44 x 49 (787 x 1118 x 245)
Motor – HP (kW)	1.5 (1.12)
Wash Speed – RPM	43
Distribution Speed – RPM	92
Extraction Speed – RPM	525
Extraction G-Force	80
Static Weight – lbs (kg) ⬥	821 (373)
Max. Dynamic Load RMS – lbs (kg) ⬥	632 (287)
Frequency (Hz)	8.83
Water Pressure ^(Required) – psi (bar)	5-75 (0.3-5.1)
Water Valve CV Rating – gal/min (L/min)	1.5 (5.7)
Minimum Recommended Distance Between Machines – ins (mm)	0 (0)

ELECTRICAL SPECIFICATIONS

Voltage	Running Amps	Fuse (Amps)	Circuit Breaker (Amps)
220/3/50	5	FRN10	10
208,240/1-3/60	6/5	FRN10	10
380/3/50-60	4	FRS8	8
415/3/50	3	FRS6	6
480/3/60	2.5	FRS6	6

See Fuse and Wire Size manual MAEFUSE1BE for safety information.

▼ See dimensional drawing for complete details.

⬥ It is the sole responsibility of the owner/user to assure that the floor and/or any other supporting structure exceeds not only all applicable building codes, but also that the floor and/or any other supporting structure for each washer-extractor or group of washer-extractors has sufficient strength and rigidity (i.e., a natural or resonant frequency many times greater than the rotational machine speed with a reasonable factory of safety) to support the weight of all the fully loaded machine(s) including the weight of the water and goods, and including the published 360° rotating sinusoidal RMS forces that are transmitted by the machine(s). Contact the factory for additional machine data for use by a structural engineer.



MWR16E5

35 LB. (16KG) CAPACITY
RIGID-MOUNT WASHER-EXTRACTOR

SPECIFICATION SHEET

Standard Features:

- 3 speeds
- E-P OneTouch® programmable controller
- Single-motor inverter drive
- Tall, lifting ribs
- Sealed ball bearings
- High M.A.F. (Mechanical Action Factor)
- Large cylinder perforations
- Fresh-water flushing chemical manifold
- Auto tension V-belt drive
- Three (3) liquid chemical injection ports
- Control reads in English/second language
- 5-year limited warranty on frame, cylinder & shell



Optional Features:

- Lint trap
- Mounting base, 10" or 6"

Why Purchase Milnor?

- Greater cylinder perforated-area generates *better wash quality, better rinsing and better extraction.* **BENEFIT: Better extraction saves dryer fuel.**
- Faster process times reduce fabric wear, promoting *longer linen life!* **BENEFIT: Saves linen replacement costs.**
- Tall perforated ribs provide excellent lift and high drop. **BENEFIT: Greater mechanical action (M.A.F.) leads to better wash quality.**
- 80-G extract provides excellent moisture removal. Lower extract speeds are available for uniforms, delicate textiles and blended fabrics. **BENEFIT: Better extraction saves dryer fuel.**
- Simple, push-button controls allow for four separate wash formulas. Indicator lights signal when machine is in operation and prompts operator when machine is moving into final wash formula stage. Shortens training time of new employees. **BENEFIT: Fewer operator errors.**
- Superior product support through local, highly-skilled dealers. **BENEFIT: Faster repairs mean less downtime.**



Safe chemical injection



Superior cylinder design

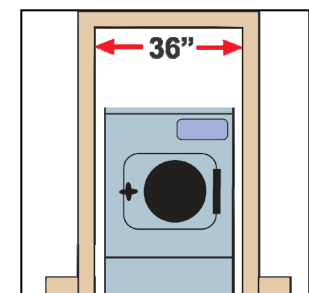

Fits through a 3'-0" door

Contact Milnor for your local, authorized dealer:

Pellerin Milnor Corporation
P.O. Box 400 • Kenner, LA 70063
t: 504-467-9591 • f: 504-468-3094

